

Phased Spaced Active Whips and Broadband Loops

Mark Connelly, WA1ION – 30 JUL 2002

During March 2002, I did an extensive series of tests at East Harwich, MA on the phasing of two identical compact antennas (first active whips, then broadband loops). The spacing between the two spaced antennas was approximately 50 m (164 ft.) on an east-west axis.

A good rule of thumb is $1/12$ wavelength minimum spacing, $1/3$ wavelength maximum spacing. The ideal value for a cardioid pattern is $1/4$ wave spacing (or odd multiples thereof) and $+90$ or -90 degrees of phase shift (as supplied by the combination of feedline lengths and phasing unit delay adjustments). $1/8$ wavelength, requiring 135 degrees of shift, still works reasonably well. Closer spacings require more phase shift, going towards 180 degrees. If the antennas are too close, signals from all directions null together: not very useful ! If the spacing is increased to a half-wave (or integer multiples thereof), 0 degrees of phase shift would be required and the pattern formed would have a bi-directional null (i.e. figure-of-eight rather than cardioid).

With the medium wave range of 500 to 2000 kHz, $1/12$ wavelength at 500 kHz and $1/3$ wavelength at 2000 kHz both equate to 50 m, so this is a good midrange spacing value. Separation in the 60-100 m range could work slightly better at the bottom of the AM broadcast band. The effect being exploited is that signals from the east arrive at the east end antenna before they reach the antenna at the western end. The converse is true for signals coming from the west.

The test set-up is shown below:

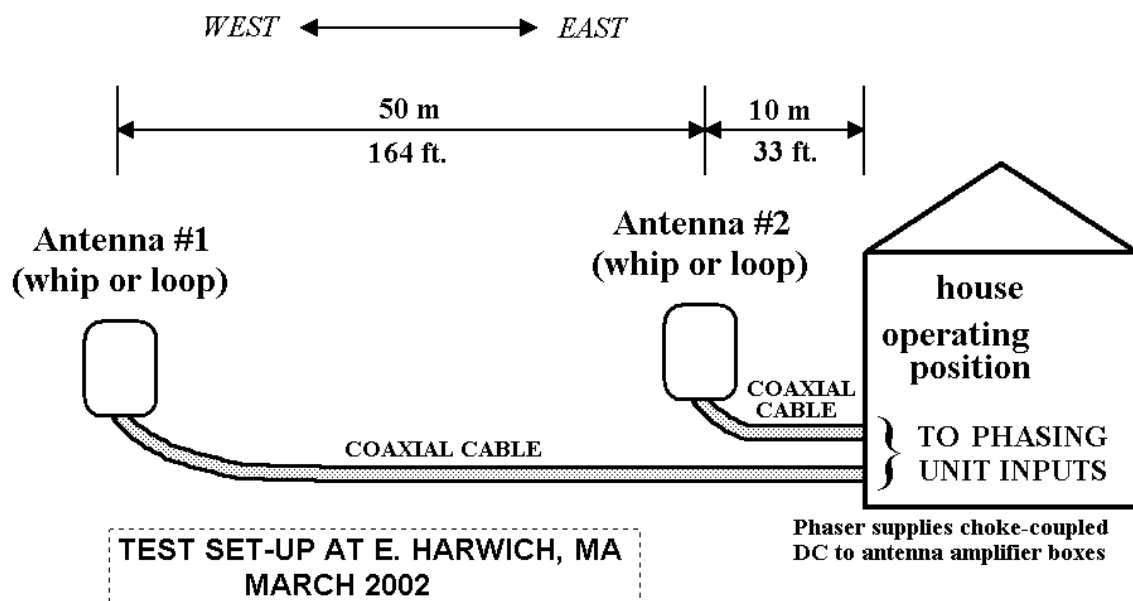

Field-site antenna amplifier boxes were TMB-1's (*reference 1*). These can be used in one configuration for active whip operation (I used a 1.83 m / 6 ft. telescoping rod) and in another configuration for broadband loop operation (using, in this case, a 2 m per side square loop of wire mounted in a vertical plane).

Besides bringing the signals of the two antennas to the phasing unit inputs, I tried an FCA-1 Feedline Coupling Adaptor (*reference 2*) on the feedline from the antenna farther from the operating position.

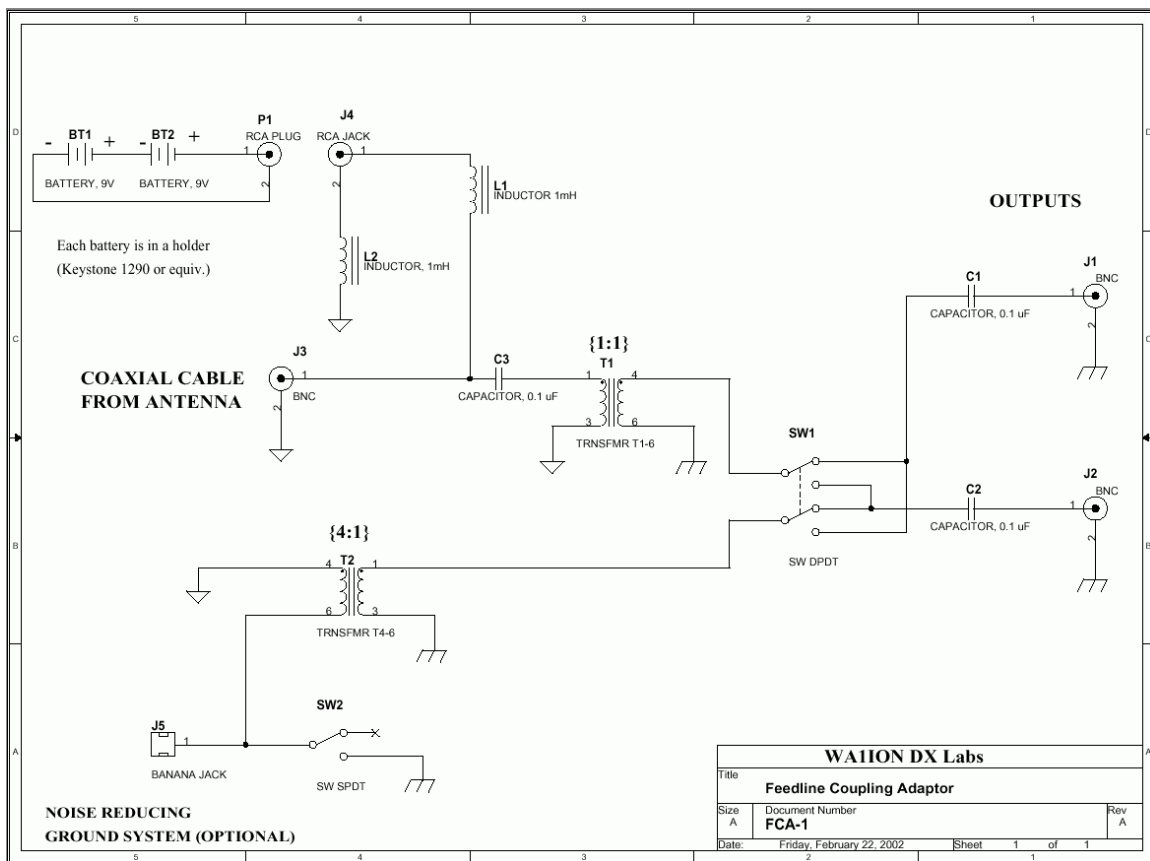

The FCA-1 allows the 60 m feedline going to the amplifier base of the farther antenna to be used as an antenna itself.

Any suitable phasing unit, such as the DXP-3 (*reference 3*), may be used.

Active Whip Tests

Two TMB-1 amplifier modules in active whip mode were used. The antenna element for each was a 1.8 m / 6 ft. telescoping rod (Radio Shack 270-1408) attached to a small plastic box fitted with a BNC-male connector to mate to the TMB-1's whip input jack.

Commercial active whips, such as the MFJ-1024, could have been used instead.

Tests were performed with each of the following antenna combinations presented to the phasing unit inputs.

<u>Set-up #</u>	<u>Phaser Input 1</u>	<u>Phaser Input 2</u>
1	active whip 60 m from house	active whip 10 m from house
2	active whip 60 m from house	60 m feedline-as-antenna
3	active whip 10 m from house	60 m feedline-as-antenna

Set-up #1 gave good cardioid results with deep nulls of stations to the west (± 30 degrees) not causing reduction of signals from the north, northeast, east, southeast, and south. Similarly, if the station to be nulled was from the east (± 30 degrees), stations in westerly directions were affected to a very minimal amount. In fact, if anything, stations from directions opposite the cardioid null were often enhanced in strength slightly as compared to their strengths on one whip or the other used singly. Below 700 kHz, there were a few cases where opposite-direction signals went down slightly in strength during nulling. This problem would go away with a bit greater spacing between the active whips.

If set-up #1 was phased to null stations close to perpendicular to its axis, a bi-directional null results. Since there is no difference in time of arrival of a given northern or southern signal's time of arrival at the two antennas, two whips spaced on an east-west axis will produce an east-west peak / north-south null (figure-of-eight) if the phasing unit is adjusted for nulls of stations close in bearing to either north or south. This predicted behavior was found to be generally true during the East Harwich tests: south-bearing stations from the Caribbean (e.g. ZIZ-555 St. Kitts-Nevis) weakened when stations from the north (e.g. WGAN-560 Maine) were nulled. To null WGAN without weakening ZIZ, the better configuration would be to space the active whips on a north-south axis.

Set-ups #2 and #3, the phasing of the feedline against one or the other antenna, turned out to be useful. These two set-ups gave similar performance to each other, though – from the standpoint of local electrical noise – the preferred configuration would be the use of set-up #2 employing the active whip antenna farther from the house. Unlike the active whip's omnidirectional characteristic, the feedline-as-antenna has some inherent directivity. Some moderate amount of nulling occurs at a right angle to the feedline. The almost-on-ground "feedline antenna", as any low longwire substantially shorter than a Beverage, looks a bit like a loop in its pick-up characteristic: a loose figure-of-eight with shallow nulls (north-south in the E. Harwich test case) and slight peaks along the line of its axis (e.g. east-west). The peak in the direction away from the receiver end may be slightly greater. The antennas may differ in response to local noise sources. Another

interesting observation is that, since the feedline is close to the ground, its low vertical angle pick-up is poorer (relative to short skip) than that of the active whip. Because of these differences in pick-up, useful nulls can be obtained with active whip versus feedline antenna phasing. Results are cardioid performance for east-west situations, much like the two spaced active whips. It's also rather like loop-versus-whip phasing, whether there's any spatial separation between those antennas or not. The feedline antenna, in this case already provides some nulling north and south. Any further nulling in those directions is provided by adding in a very attenuated sample of phase-shifted RF from the active whip. The resultant pattern is still essentially a north-south nulling figure-of-eight, or something close to it.

More interesting is the diversity in skip angle pick-up in the vertical plane. Cancelling high-angle skip (such as Albany, NY on 1540 kHz and New York City on 1560) can be done with set-ups #2 or #3 without causing much degradation of lower angle more-distant skip even if it is coming from a direction not greatly different from that of the high-angle signal. That's because the feedline antenna is not picking up as much low-angle skip as the whip (relative to high-angle pick-up). When the high-angle component from the feedline antenna is shifted to be +/-180 degrees in phase relative to the pick-up of the same signal by the whip, less low-angle signal is cancelled even if it too is at a 180 degree phase shift. Some nulls of high-angle skip have been greater in depth and stability with set-ups #2 and #3 than with set-up #1. This initial observation during the E. Harwich tests was noted again with similar antennas during DXpedition activity at the salt-marsh site in Rowley, MA on several subsequent occasions. Sometimes set-up #1, the two spaced phased vertical whips, gave the optimum results in nulling US interference to European DX signals, sometimes set-up #2 or #3, whip-versus-feedline, did better. It is certainly beneficial to have the FCA-1 available to enable all of these approaches.

Broadband Loop Tests

Each active antenna consisted of a TMB-1 amplifier base in broadband loop mode with a loop head consisting of an 8 m (26.25 ft.) wire formed into a square 2 m (6.56 ft.) per side and supported on a wooden frame. This square was mounted in a vertical plane and was oriented either to null north-south (peak east-west) or to null east-west (peak north-south), as indicated in the set-up table below. Connections of the two ends of the loop head wire to the TMB-1's inputs were made at a break in the loop wire at the midpoint of the bottom side of the square.

There is no reason that a Wellbrook ALA-1530 or the Graham Maynard '6x6' broadband loop could not have been used instead. Results would be similar.

Tests were performed with each of the following antenna combinations presented to the phasing unit inputs.

<u>Set-up #</u>	<u>Phaser Input 1</u>	<u>Phaser Input 2</u>
4	broadband loop (N-S null) (60 m from house)	broadband loop (N-S null) (10 m from house)
5	broadband loop (N-S null) (60 m from house)	60 m feedline-as-antenna
6	broadband loop (N-S null) (10 m from house)	60 m feedline-as-antenna
7	broadband loop (N-S null) (60 m from house)	broadband loop (E-W null) (10 m from house)
8	broadband loop (E-W null) (60 m from house)	broadband loop (N-S null) (10 m from house)
9	broadband loop (E-W null) (60 m from house)	broadband loop (E-W null) (10 m from house)
10	broadband loop (E-W null) (60 m from house)	60 m feedline-as-antenna
11	broadband loop (E-W null) (10 m from house)	60 m feedline-as-antenna

Set-up #4 is very valuable in that the loops separated on an east-west axis and aligned for north-south nulling will produce a tighter cardioid pattern than that produced by the two separated active whips. This is because the loops inherently remove some of the interference from the north and the south: something the whips don't do. When you adjust the phasing unit to place a null towards interfering stations to the west, stations coming in from the east are in a peak that is more "narrow nosed" than that produced by the phased whips of set-up #1.

The same applies to stations from the east being phase-nulled to hear stations from the west better. Since, right out of the starting gate, this set-up has less north-south pick-up than the whips, general levels of interference to the desired-direction DX will be lower.

Loops don't have quite as good low-angle pick-up (relative to high-angle skip) as the vertical whips do, so that might be somewhat of a drawback, especially with pre-sunset

Transatlantic DX at receiving sites in eastern North America, or post-sunrise Transpacific DX from the West Coast.

Elevating the loops may offer some low-angle pick-up improvement. Hoisting one of the loops to the 18 m height level (rope over top of pitch pine tree) in a temporary experiment improved its low-angle pick-up a bit and reduced some local electrical noise relative to its pick-up at a nearby mounting location (base less than 2 m above ground). Conceivably you could get some interesting effects by phasing a highly-elevated loop (30 m minimum height) versus one near the ground, whether or not there is any horizontal separation. This was not tried for lack of time and support height: maybe one of the EZNEC experts could model it.

For many, phased loops schemes will be winners because loops pick up less locally-produced electrical noise than vertical whips do.

Set-ups #5 and #6, phasing the feedline antenna against the loop at one end or the other, was not terribly useful. The feedline's pick-up is somewhat like that of an east-west loop halfway between the two loops (because of the averaging of its pick-up). This would reduce its "effective spacing" to be about 25 m from either loop. Except perhaps for 1500 kHz and above, this isn't enough spacing to prevent a lot of desired-direction "collateral nulling" when opposite direction interference is being phased out. If the feedline was about twice as long, set-ups #5 and #6 would have produced more worthwhile results.

Set-ups #7 and #8, phasing orthogonally-oriented loops, gave good nulling results, particularly along the bisectors of the angles between them. In these cases, this meant that signals from the northwest could be nulled to reduce interference to signals from the southeast, and vice versa. Similarly, signals from the northeast could be nulled to reduce interference to signals from the southwest, and vice versa. When a station to be nulled was close in bearing to the inherent null of one loop or the other (due north-south and east-west in these tests), a small sample of out-of-phase signal from the other loop could be added to deepen this null, but opposite-direction signals would also be reduced (i.e. figure-of-eight produced) rather than yielding the single-side null cardioid results obtained with nulling along the bisector lines. The spacing between two loops at a right angle is not critical: they can be mounted very close to each other (as in a goniometer) and useful nulling can still be obtained since their pick-up patterns are different.

Set-up #9 produces a north-south peaking figure-of-eight that can be somewhat narrower than what is produced singly by each loop. Residual east-west pick-up that is not completely nulled by the loop elements themselves can be reduced further by phasing. With this configuration, even better results can be had with greater spacing (in the vicinity of a half-wave).

Set-ups #10 and #11 produce results akin to those of the two loops at a right angle (set-ups #7 and #8) except that you now have some diversity in the vertical skip angle and noise pick-up profiles between loop and feedline antenna types. This could yield some

nulls that the two-loops schemes might not, especially if one's main focus is "noise-busting".

Horizontal Loop: any value to this ?

A horizontal plane square loop is omnidirectional like a vertical whip. It has inferior low-angle pick-up compared to the whip. It may, in some circumstances, reject local electrical noise better. Phasing such a loop against either a whip or a vertical-plane loop separated 50 m or so may yield beneficial nulls. I haven't tried this yet.

Broadband Loop versus Active Whip ... a few comments

A vertical-plane square or circular broadband loop can be phased against an active whip with excellent results. The spacing between these can be quite small since the inherent figure-of-eight pick-up of the loop is sufficiently different from the omnidirectional pattern of the vertical whip. This is the set-up I often use on the roof of the car at beach DXpeditions where there isn't any room for more space-hungry approaches. This configuration produces cardioid peaks-nulls along the two bearings of the loop's maximum pick-up (+/- 30 degrees or so) and enhances the loop's figure-of-eight nulls in directions close to those that the loop nulls on its own. Since most of my listening involves reducing stations to the west to improve incoming European, Middle Eastern, African, and Brazilian stations (on bearings between northeast and southeast), I orient the roof-mounted broadband loop to peak east-west and then phase its output against that of the active whip to reduce signals from the west (+/- 30 degrees). Many sunset listening sessions at coastal sites in the northeastern USA have validated the usefulness of this method.

Passive Versions of Broadband Loop and Whip for City-Dwellers

Even the best broadband amplifier designs are going to be challenged in the strong-signal urban environment. Intermodulation products and harmonics are apt to occur. Narrowly-tuned versions of the antennas are one way to mitigate the problem, but this leads to poor frequency agility and inefficient operation. To keep things broadband, passive matching transformer techniques can be used instead.

A whip can be coupled to coaxial line through a 36:1 or other high-ratio transformer. A hand-wound version on a large ferrite core of #43, #75/J, or #77 material is preferable to the small chip-sized Mini-Circuits equivalents (e.g. T36-1-X65). If the vertical antenna element is made appreciably large (at least 6 m), the signal transfer will be greater and the passive matching transformer ratio can be brought down to something like 16:1 or 9:1. The ground connected to the end of the high-impedance transformer primary winding (on the other end of the winding to the antenna) can be the coaxial shield's ground or, for lower noise, independent ground rods or radials near the base of the vertical. You could also use a transformer at the center of a vertical dipole: use a 16:1 or other high ratio if the overall dipole length is considerably shorter than a resonant half-wave.

As in the whip case, a broadband loop intended for passive coupling should be made physically larger than its amplified version. The two leads from a square 4 m on a side (16 m total wire) can be coupled via a 4:1, 2:1, or 1:1 transformer to the coaxial line. As noted before, use a large toroidal core if core-saturation intermodulation is likely with something smaller.

Passively-coupled antennas are more weatherproof than ones with outdoor “head-end” amplifiers. Amplification, whether broadband or tuned, can be applied in a controlled environment at the operating position if required.

References

Web links are current as of 30 JUL 2002. In future, if these are not valid, use a search engine to find the documents on-line. Alternately, it may be possible to procure them on paper from the National Radio Club or International Radio Club of America reprints services.

1. “TMB-1 Tri-Mode Buffer Amplifier Box”, Mark Connelly, 3 APR 2002
HTML: <http://www.qsl.net/wa1ion/tmb-1/tmb-1.htm>
PDF: <http://www.qsl.net/wa1ion/tmb-1/tmb-1.pdf>
2. “FCA-1 Feedline Coupling Adaptor”, Mark Connelly, 22 FEB 2002
HTML: <http://www.qsl.net/wa1ion/coupler/fca-1.htm>
PDF (schematic only): http://www.qsl.net/wa1ion/coupler/fca-1_f1.pdf
3. “DXP-3 DXpedition Phasing Unit”, Mark Connelly, 26 SEP 2000
PDF: <http://www.qsl.net/wa1ion/dxp/dxp3.pdf>