

POPTRONIX[®]

Electronix Handbook

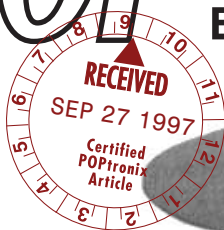

Discone VHF-UHF Antenna

The discone is a popular wide-band antenna for VHF and UHF. This article shows you how to build a very efficient one for your UHF scanner.

**BY WILLIAM SHEETS, KPMQJ
and RUDOLF F GRAF, KASCWL**

The Discone Antenna described here was designed to operate over a frequency range of 700 to 2000 MHz. It is a very small antenna, but very effective. It is vertically polarized, and has an omni-directional radiation pattern.

The antenna's two principle elements

are a flat conducting disc mounted horizontally atop, but insulated from, a conducting cone. The disc diameter is about 0.17 wavelength at the lowest desired operational frequency and the cone has a length of 0.25 wavelength on the side. The discone's impedance is 50

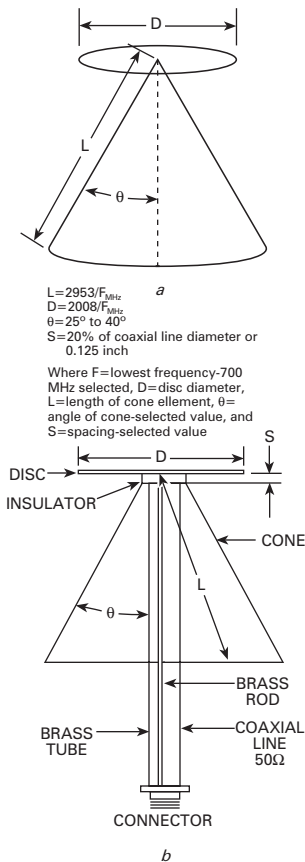

Fig. 1—DISCONE ANTENNA DIMENSIONS: a—view of idealized discone antenna and b—view of assembled antenna specified in this article. Equations can be used for assembled antenna and provide excellent reception results.

ohms, so it can be fed by a 50-ohm coaxial cable. The outer (shield) conductor is connected to the cone, the center conductor is connected to the disc. The antenna's actual impedance varies depending on the cone's angle, frequency, and disc-to-cone spacing. Nevertheless, discone dimensions are not very critical for optimum performance.

Figure 1-a is an idealized sketch of a true discone antenna and its basic dimensions. It was determined that the disc diameter should be 3 inches and the length of a side element of the cone should be 4-1/4 inches. The angle (Fig. 1-b) could be any angle between 25 to 40 degrees, so 30 degrees was selected for a practical reason.

The space created by the insulating washer (S) will be 1/5 Of the inside diameter of the brass tube (Fig. 2) or about 1/8 inch (thickness is not critical).

Construction

A piece of 5/8-inch brass tube is used to support the discone and is the outer conductor of the feedline (Figs. 1-b and 2). This tube has an inside diameter of 19/32 inch. With commonly available 1/4-inch brass rod used for an inner conductor, the section of coaxial line that results has a 52-ohm impedance.

The exact impedance is not too critical and less than 10% variation in impedance should not cause reception problems. The length of the brass tube is up to the discretion of the builder. The loss due to the added length is negligible. A 5-1/2 inch length of brass tube was used in the discone illustrated here, but up to about two feet of tubing should present no problems. Longer lengths will require some mechanical modifications in order to ensure that the line geometry remains concentric and reasonably rigid. This becomes a construction problem and should be avoided.

Theoretically, the cone of the discone should come to a point. However, it can be truncated to allow the brass tube to be soldered to it. The disc is fastened to the brass rod (Fig. 3) by a screw which fits into a tapped hole in the center conductor. A shoulder insulator made from plastic faucet washers keeps the brass rod concentric with the inner wall of the brass tube and provides a spacing between the disc and cone of about 0.125 inch. The bottom end of the line section is soldered to a type N UHF connector. A small clamp or U bolt can be used to mount the antenna to a mast.

Sheet metal work

The disc and cone were cut from 0.019-gauge copper flashing stock (Fig. 2) purchased from a local plumbing supply house. Since the angle selected is 30 degrees, a half-circle pattern is needed to form the cone. Cut the cone and disc according to pattern. A little overlap tab, as shown in Fig. 2, allows for soldering after the cone is formed. Use shears and wear heavy gloves as copper tends to cut flesh with sharp razor-like edges. File all edges smooth.

The cone is formed by first drawing radial lines on the inside surface, bending the pattern a little at each line around a block of wood or steel, and repeating the process until the pattern edges meet. The cone should be a fairly good, even, circular shape. Make sure the hole at the top will fit the 5/8-inch brass tube snugly. Clean the edges and soldering surfaces with fine (No. 0) steel wool. Clamp the edges of the cone together with the tab underneath and solder using 60/40 solid-core solder and liquid flux. Next, clean the brass tube with fine steel wool and solder the cone to the brass tube as shown in Fig. 3. Make sure the brass tube is symmetrical and concentric in the cone. Carefully clean all flux residues using hot water and baking soda, followed by a final rinse in hot water.

Cut the brass rod to the same length as the brass tube. Drill a #36 hole in each end 1/2-inch deep. Use a drill press if possible, and center punch each end to prevent the

drill from "walking". The rod has to be held by a vise or clamp to do this. Tap one end of the brass rod for a 6-32 screw thread.

Make a shoulder-washer insulator as shown in Fig. 2 from two plastic washers. The top larger washer should be 3/4-inch diameter by 1/8-inch thick and the center hole should be large enough to pass a 6-32 screw (#28 drill hole), but not larger than 3/16 inch. The bottom washer should be press fit into the brass tube whose inside diameter is 19/32 inch. The center hole should be 1/4-inch diameter to pass the 1/4-inch brass rod. Glue the washers together to form a shoulder washer. Now trial fit the entire discone assembly together. Trim the length of the center conductor so the top of the shoulder washer rests on the end of the brass tube. When the parts fit properly, you are ready to solder. Clean the brass rod and the rear of connector flange with fine steel wool. The surfaces should be shiny. Using 60/40 rosin core solder, solder the untapped end of the brass rod to the type N UHF connector's center pin. Use at least a 100-watt soldering iron. Next, insert this assembly into the lower end of the 5/8-inch brass tube. Insert a 6-32 by 1/2-inch long, brass, roundhead screw through the center of the copper disc, the insulator, and into the tapped hole in the end of the brass rod. Tighten the screw enough to hold the parts together and hold them in place for soldering. Make sure the brass tube is centered on the flange of the connector. Now, solder the connector's flange to the brass tube all around the seam. Use only enough solder to do the job. Check for shorts with an ohmmeter. There should be an infinite resistance between the disc and cone, and the center terminal and flange of the type N connector. Next, check that zero resistance (short circuit) exists

between the disc and the center terminal of the connector.

Clean all flux residues and the discone construction is done. Alcohol is good for removing rosin flux. Clean with alcohol only outdoors and away from fire as

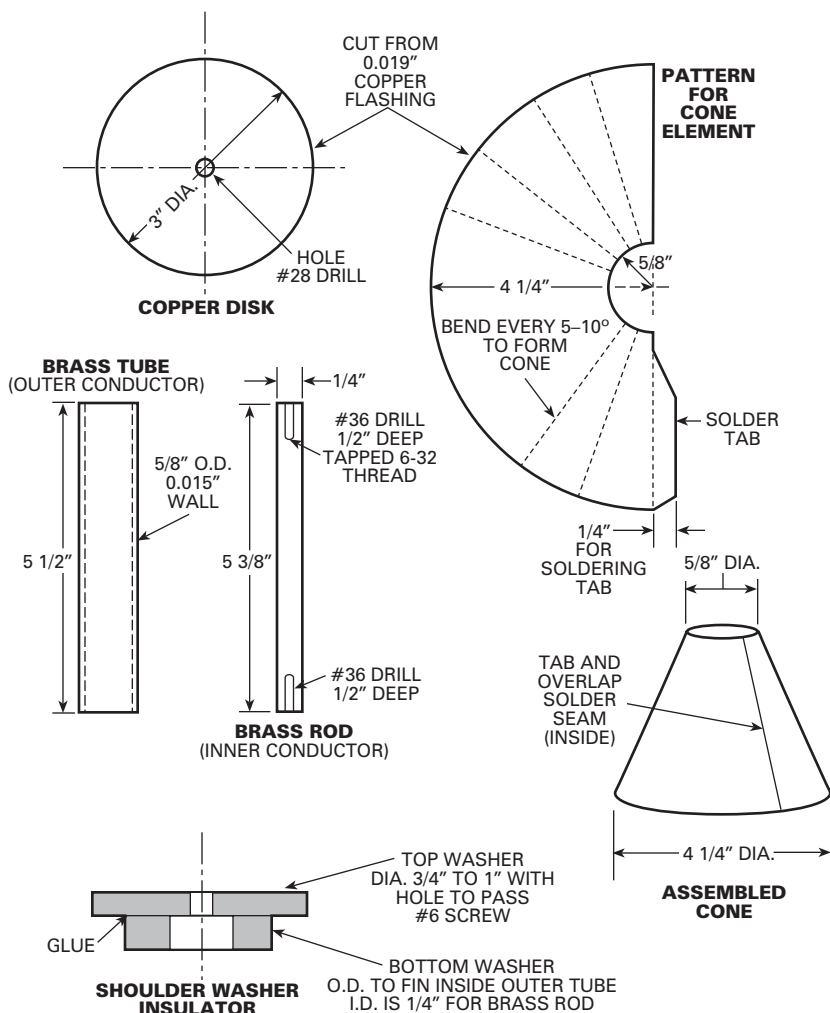

Fig. 2.—
CONSTRUCTION
PARTS DETAILS for
a 700-2000-MHz
UHF discone
antenna.

alcohol can be toxic and is highly flammable.

If you have suitable equipment, check the antenna's VSWR at the frequencies of interest. The prototype's measured VSWR was found to be better than 1.5 to 1 at 910 and 1289 MHz. The use of type N connectors in the test cable setup is preferred.

Mount it

The discone can be mounted to a mast with clamps. Fasten clamps around lower

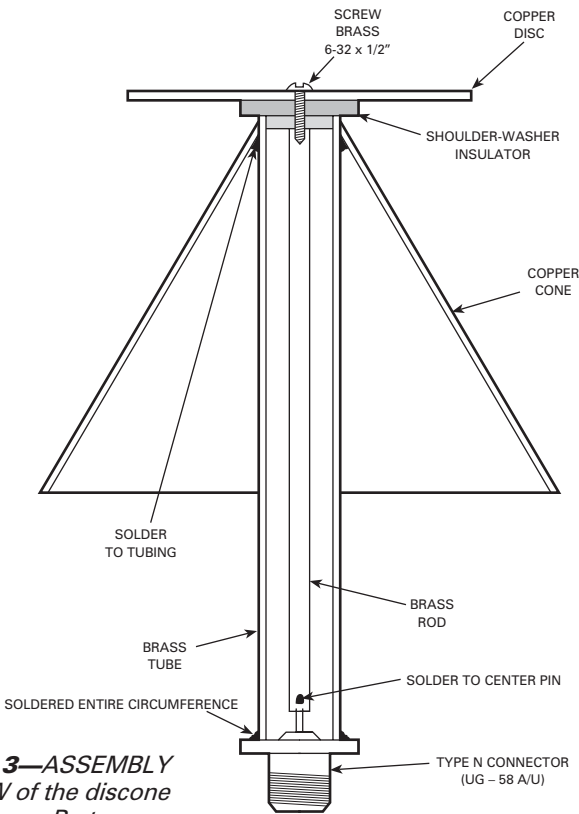

Fig. 3—ASSEMBLY VIEW of the discone antenna. Parts should fit firmly together before soldering is attempted. Clean surfaces to be soldered to a bright shine with #0 steel wool.

end of brass tube, being careful not to dent or crush it. You can use small metal or plastic cable clamps as the antenna is very light, or it can be plugged directly into the scanner antenna jack. Use a right-angle adapter. When the antenna was used with a pocket scanner, excellent reception results were obtained on 860 and 935 MHz commercial signals, much better than the 8-inch "rubber ducky" original equipment. Also, a marked reduction in intermodulation and cross modulation effects was noted. Although below the cutoff frequency, satisfactory 450-MHz reception was also obtained. For optimum 450 MHz performance, increase the cone and disc dimensions 75%.

In field tests, the discone assembled by the authors outperformed a 24-inch commercial discone sold for scanner

reception at 900 MHz. This is probably because the home-built discone has a lower wave angle and because it is constructed of solid copper elements, with resulting lower losses. Improvement on reception and transmission was about 3 dB. The discone was used with success as an antenna for experimental amateur TV transmissions at 900 and 1300 MHz.

LIST OF MATERIALS

- 1—Brass tube, 5/8-in. (0.015-in. wall), 5-1/2-in. long
- 1—Brass rod, 1/4-in., 5-3/8-in. long
- 1—Copper or brass sheet, 0.019 to 0.030-in. thick, approximately 5 x 12 in.
- 1—Type N UHF connector, UG58A/U, preferably silver plated
- 2—Plastic faucet washers (3/4 to 1-in. dia.) with hole for #6 screw or smaller (drill and file to sizes in Fig. 2)
- 1—6-32 x 1/2-in. brass machine screw, Phillips or slotted head
- 2—Pipe clamps to fit 5/8-inch OD tube (plastic preferred) for mounting antenna.

Parts and materials not normally stocked by electronic parts stores can be obtained at hobby shops specializing in model aircraft and/or cars, plumbing supply outlets and hardware stores.

A catalog describing kits for ATV transmitters, ATV receiving converters and other projects usable with the antennas described in this article is available from:

North Country Radio
PO Box 53
Wykagyl Station
New Rochelle, NY 10804

Please include a #10 SASE and \$1.00 to cover handling and postage.

E-mail: Ncradio200@aol.com or CompuServe 102033,1572

Copyright © 1997, POPtronix Inc.
All rights reserved.

As a service to readers, POPtronix, Inc. publishes available plans or information relating to newsworthy products, techniques and scientific and technological developments. Because of possible variances in the quality and condition of materials and workmanship used by readers, we disclaim any responsibility for the safe and proper functioning of reader-built projects based upon or from plans or information published online.

Since some of the equipment and circuitry described in POPtronix, Inc. Project Articles may relate to or be covered by U.S. patents, we disclaim any liability for the infringement of such patents by the making, using, or selling of any such equipment or circuitry, and suggest that anyone interested in such projects consult a patent attorney.